

TRI-STAR 26MT - CRUISING - RACING - TRAILERABLE

COPYRIGHT RESERVED
The Design and the Plans remain the property of the Designer and are to be used only by authorization of the Designer. In using these Plans the Builder agrees to give a Receipt, on each vessel started and to use or to permit the use of the Plans or Design only as authorized by the Designer.

TRI-STAR TRIMARANS/CATAMARANS



LOA 26' (7.92M). LWL 25'6" (7.77M).
BEAM 16'8" (5.08M). BEAM TRAILERING
8'5" OR 8' (2.56M or 2.44M).
DRAFT 19" (.48M). DRAFT DAGGER BOARD 3' (.91M).
LAUNCH DISPLACEMENT 1750# (795K).
USEFUL LOAD 1150# (522K).
SAIL AREA 415 FT.SQ. (38.5M.SQ.).

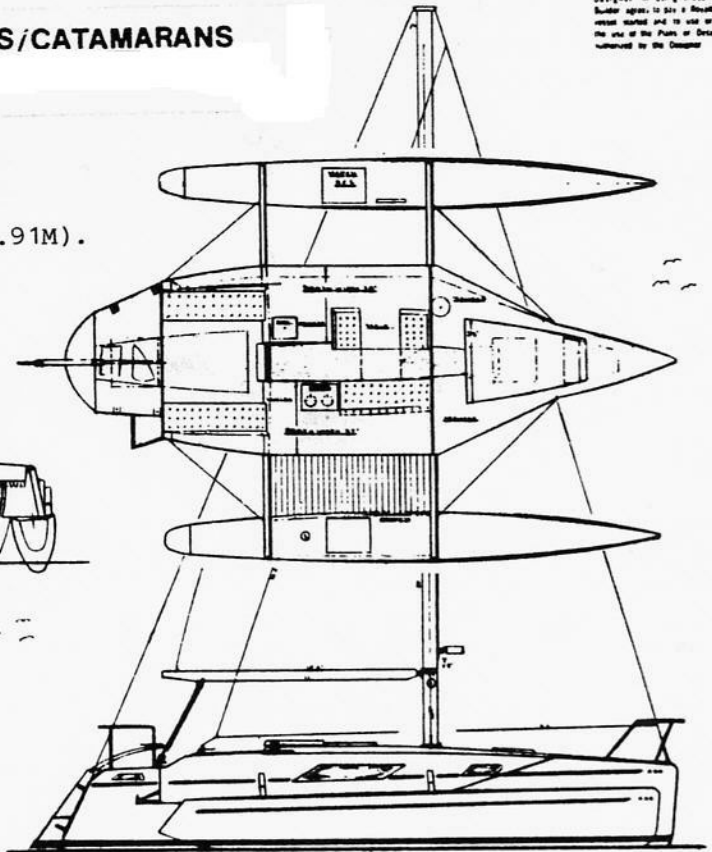
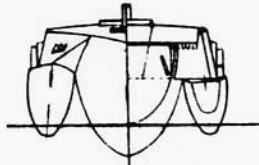
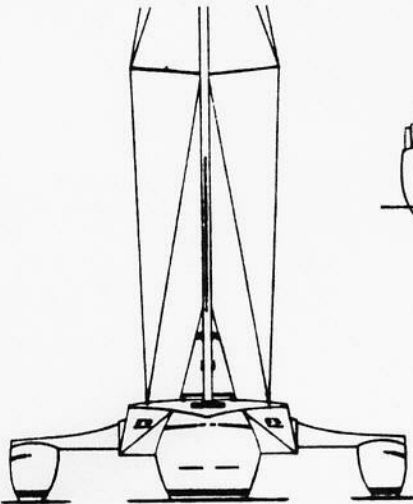

TRI-STAR 26MT a trailerable trimaran designed by Ed Horstman to fit into the rapidly expanding Micro Multihull Class. = 26MT. The Micro class evolved because in the 26' range you can have comfortable cruising accommodations and the water line length for class racing performance while not experiencing the cost spiral of the larger classes. TRI-STAR 26MT is designed with comfort and performance in mind for the cruiser or racer. The 26MT may be built at a reasonable cost and be stored in one's own back yard. Accommodations are unsurpassed in its class with four full size berths in the main hull. The forward berth may be called a private double berth. There is a water closet under the forward berth. The aft berth is it's own private "state room" accessible from both the cabin or through the aft deck hatch. The aft berth and the fwd berth have hull sit up headroom. The 26MT may be said to have two "private state rooms" plus an open galley and dinettes that may be two berths. The pop top galley hatch gives full headroom when in the galley. On deck the spacious cockpit is over 4' long and you may sit on the aft cabin top thus you have seating for 6 or more. A boom tent covers the cockpit in port. The forward flush deck is easy to move about on and everyone enjoys the 26MT's small amount of sailing heel.

TRI-STAR 26MT main hull and amas have been designed for performance and are powered with a high aspect ratio sail plan that may have a self tending jib for easy family sailing, For more performance a furling head sail is used. The 26MT performance may be optimized for racing with a full battened main sail which should make the 26MT into a formidable sailing machine. TRI-STAR 26MT is a trailerable design with the amas being folded back under the main hull for trailering. The amas may be easily folded or extended in the water or on land and when folded the 26MT easily fits in a regular boat slip. You will find the 26MT easy to build using either molded plywood or foam fiberglass sandwich construction and plans come with full size patterns. TRI-STAR 26MT is an affordable, comfortable, performance sailing Tri-Star Trimaran that you will enjoy owning and sailing. Happy Sailing.